

Technical data on page 38

gR

 RATED VOLTAGE
 ~500V

Technical data:

 Standards:
 IEC 60269-4

 Breaking capacity:
 ~50kA / --- 8kA
 Rated voltage:
 ~500V / --- 315V

Application:

Fuse-links of system D are mounted in fuse base E16, E27, E33, R 1 1/4", R2".

Size	In (A)	Type	Code No.	Operating I ² t-value (A ² s)	Power dissipation	Char.	Colour	Dimension B	Packaging (pcs)	Weight (g)
D I	2	DIUQ2A	004321001	5,8	2,1	gR	pink	6	10/500	12
	4	DIUQ4A	004321002	11	2,5	gR	brown	6	10/500	12
	6	DIUQ6A	004321003	18	3,2	gR	green	6	10/500	12
	10	DIUQ10A	004321004	40	3,6	gR	red	8	10/500	13
	16	DIUQ16A	004321005	60	6,3	gR	grey	10	10/500	14
	20	DIUQ20A	004321006	139	7,3	gR	blue	12	10/500	15
	25	DIUQ25A	004321007	205	9,0	gR	yellow	14	10/500	16
D II	2	DIUQ2A	004322001	5,8	2,1	gR	pink	6	5/500	27
	4	DIUQ4A	004322002	11	2,5	gR	brown	6	5/500	27
	6	DIUQ6A	004322003	18	3,2	gR	green	6	5/500	27
	10	DIUQ10A	004322004	40	3,6	gR	red	8	5/500	27
	16	DIUQ16A	004322005	60	6,3	gR	grey	10	5/500	28
	20	DIUQ20A	004322006	139	7,3	gR	blue	12	5/500	29
	25	DIUQ25A	004322007	205	9,0	gR	yellow	14	5/500	30
D III	30	DIUQ30A	004322008	310	10,0	gR	black	14	5/500	30
	35	DIUQ35A	004323001	539	12,0	gR	black	16	5/500	48
	50	DIUQ50A	004323002	1.250	19,0	gR	white	18	5/500	49
D IV	63	DIUQ63A	004323003	1.890	23,0	gR	copper	20	5/500	52
	80	DIUQ80A	004324001	4.200	33,0	gR	silver	5	3/48	105
	100	DIUQ100A	004324002	8.450	51,0	gR	red	7	3/48	110
D V	125	DVUQ125A	004325001	16.000	60,0	gR	yellow	5	10/60	185
	160	DVUQ160A	004325002	24.000	71,0	gR	copper	7	10/60	210
	200	DVUQ200A	004325003	40.000	90,0	gR	blue	9	10/60	215

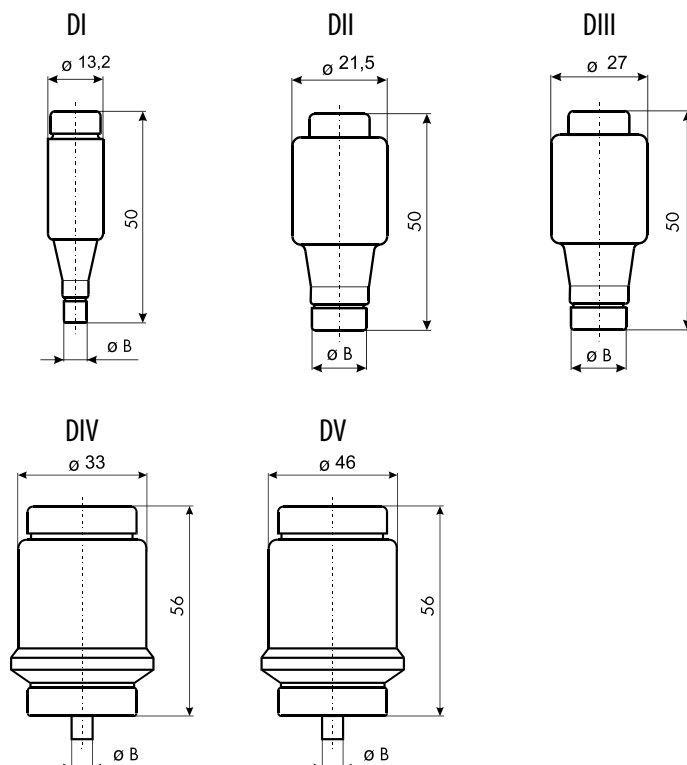
Dimensions:

DIUQ4A



DIUQ16A



DIUQ35A



DIUQ80A



DVUQ200A



ULTRA QUICK

RATED VOLTAGE
~500V

Time/current characteristics of fuse-links Ultra Quick DI, DII, DIII, DIV, DV.

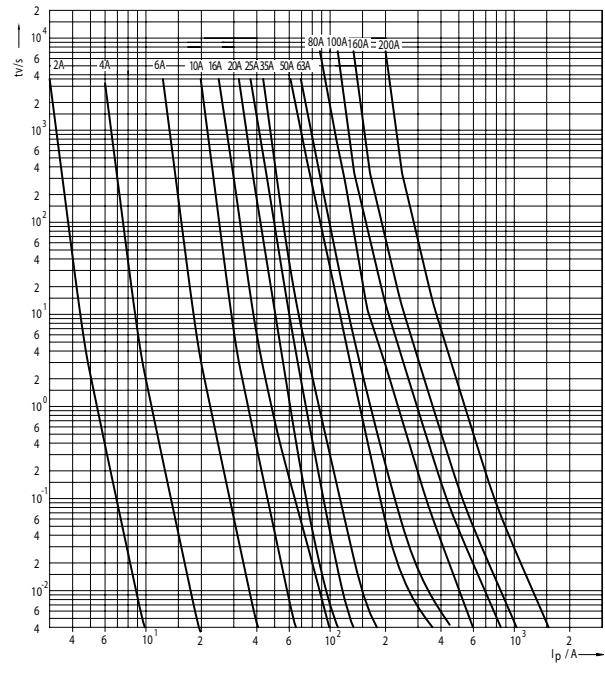

Cut-off characteristics of fuse-links Ultra Quick DI, DII, DIII, DIV, DV.

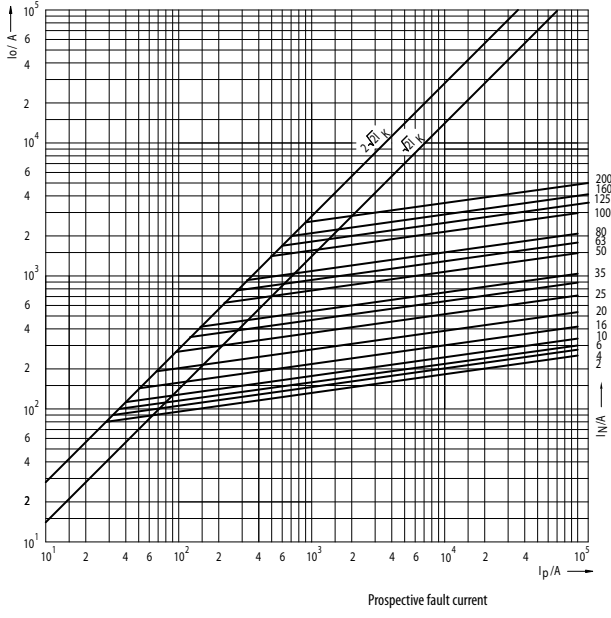

Operating Joule Integral (I²t) for Ultra Quick DI, DII, DIII, DIV, DV

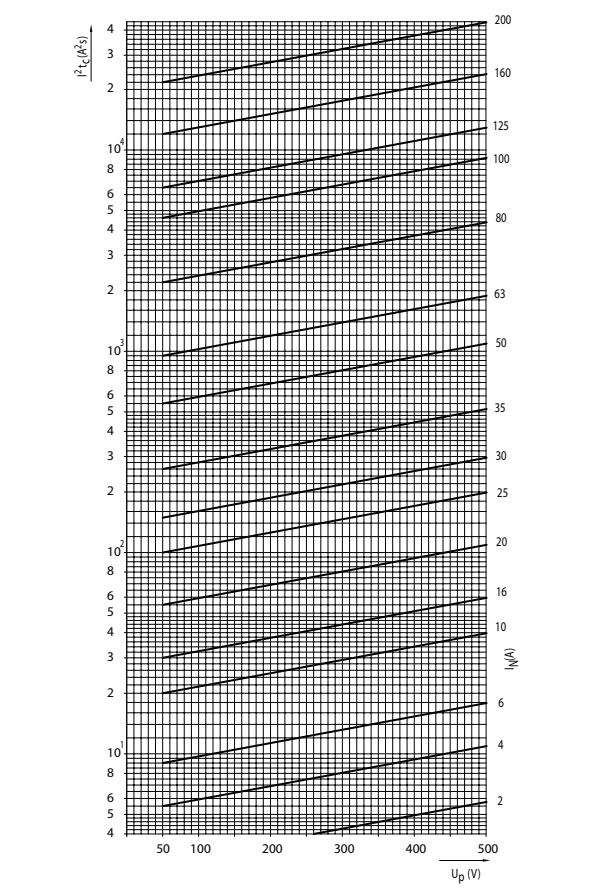

Power dissipation, pre-arcing Joule Integral and Operating Joule Integral for Ultra Quick DI, DII, DIII, DIV, DV.

I _n	Power	Pre-arcing Joule integral I ² t (1ms)	Operating Joule Integral I ² t ~125V	Operating Joule Integral I ² t ~250V	Operating Joule Integral I ² t ~500V
A	W	A ² s	A ² s	A ² s	A ² s
2	2,1	0,7	1,8	3,5	5,8
4	2,5	1,8	4,1	6	11
6	3,2	4	6	10	18
10	3,6	8	12,5	23	40
16	6,3	16,2	34	40	60
20	7,3	35,8	67	85	139
25	9,0	48,9	85	116	205
30	10,0	85	120	170	310
35	12,0	135	220	300	539
50	19,0	340	600	780	1.250
63	23,0	530	850	1.115	1.890
80	33,0	980	1.480	2.110	4.200
100	51,0	1.950	3.000	4.200	8.450
125	60,0	3.100	4.300	6.000	16.000
160	71,0	10.000	12.000	18.000	24.000
200	90,0	17.000	22.000	31.000	40.000